



Industrie Service

EU TYPE-EXAMINATION CERTIFICATE

According to Annex IV, Part A of 2014/33/EU Directive

Certificate No.:	EU-OG 068
Certification Body of the Notified Body:	TÜV SÜD Industrie Service GmbH Westendstr. 199 80686 Munich – Germany Identification No. 0036
Certificate Holder:	BODE Components GmbH Eichsfelder Str. 29 40595 Düsseldorf – Germany
Manufacturer of the Test Sample: (Manufacturer of Serial Production – see Enclosure)	BODE Components GmbH Eichsfelder Str. 29 40595 Düsseldorf – Germany
Product:	Overspeed governor, detecting and tripping element fixed at the overspeed governor, as a part of the protection device against overspeed for the car moving in upwards direction and tripping element against unintended car movement
Type:	Typ 7
Directive:	2014/33/EU
Reference Standards:	EN 81-20:2014 EN 81-50:2014 EN 81-1:1998+A3:2009 EN 81-2:1998+A3:2009
Test Report:	EU-OG 068 of 2016-03-01
Outcome:	The safety component conforms to the essential health and safety requirements of the mentioned Directive as long as the requirements of the annex of this certificate are kept.
Date of Issue:	2016-03-01
Date of Validity:	from 2016-04-20

Achim Janocha

Certification Body "lifts and cranes"



**Annex to the EC Type-Examination Certificate
No. EU-OG 068 of 2016-03-01**



Industrie Service

1 Scope of application

1.1 Generally

1.1.1 Driving rope

Category	Round strand rope made of steel wire
Diameter	6 – 8 mm

1.1.2 Minimum tension forces (force produced by the tensioning weight, acting on the axis of rope deviating pulley)

Tensioning force determined in the test (New rope and groove)	50 N
Tension force determined by calculation (coefficient of friction $\mu = 0,09$)	467 N
Tensile force at minimum tension force	300 N

Retraction of the safety gear in both directions of rotation permissible.

The safety component can fulfil three security features (1.2, 1.3 and 1.4).

1.2 Using as an overspeed governor – permissible speeds

Permissible tripping speed	0.570 – 3.43 m/s
Permissible rated speed	≤ 2.98 m/s

1.3 Using as a part of the protection device against overspeed for the car moving in upwards direction

The overspeed governor can be used as a part of the protection device against overspeed for the car moving in upwards direction. Monitoring of upward speed will be done by overspeed governor itself and a braking device can be triggered (engaged) via the overspeed governor's electric safety device or mechanically

1.4 Using as a part of the protection device against unintended car movement by an installed anti-creep protection

Using without detection system (activation at each landing)	
Max. possible response distance**	350 mm
Theoretical tripping speed at acceleration of 2.5 m/s^2	1.32 m/s

*Response distance: Defined as the max. distance that can be covered by the lift moving away from the landing position **after the blocking device has engaged** and as caused by delay and/or other distance losses at the overspeed governor until the tensile force has built up

2 Terms and Conditions

2.1 Above mentioned safety component represents only a part at the protection device against overspeed for the car moving in upwards direction and unintended car movement. Only in combination with a braking respectively detecting component in accordance with the standard, which must be subjected to an own type-examination, can the system created fulfil the requirements for a protection device.

2.2 The adjusted tripping speed and the safety switch must be sealed against unauthorized adjustment (safety switch e.g. by colour sealing of the fastening bolts).

2.3 Rope deflection optional (but at least 180° angle of wrap).

**Annex to the EC Type-Examination Certificate
No. EU-OG 068 of 2016-03-01**



Industrie Service

- 2.4 The triggering of the safety device according 1.4 takes place by interruption of the energy supply to the magnetic coin of anti creep protection. This is not caused positive mechanically but electrically resp. electromagnetically by interruption of the energy supply to the magnetic coin of anti creep protection. However, the mechanically engagement of the device has to be absolutely guaranteed after the electrical safety device has responded. In light of the above, the device must be made to engage at each regular landing, so that the anchor plates can be checked for correct closing (e.g. micro switches resp. proximity switch). If the anchor do not perform correctly (anchors fail to close) the lift must be kept at standstill.
- 2.5 Activation of anti-creep according 1.4 will take place by every operational stop of the lift in the way such as activation is initiated before car stands still.
- 2.6 The installer of the complete lift must create an examination instruction to fulfil the overall concept of the protection device, add it to the lift documentation and provide any necessary tools or measuring devices, which allow a safe examination (e. g. with closed landing doors).
- 2.7 Fast and safe rescuing of lift passengers must be possible by suitable technical measures under all circumstances. It must be documented in the operation manual of the lift.
- 2.8 The identification drawing „overspeed governor Type 7“ including stamp dated 2016-03-01 shall be included to the EU type-examination for the identification and information of the general construction and operation and distinctness of the approved type.
- 2.9 The EU type-examination certificate may only be used in combination with the corresponding annex and enclosure (List of authorized manufacturer of the serial production). The enclosure will be updated immediately after any change by the certification holder.

3 Remarks

- 3.1 Considering the whole protection systems, it is necessary to include time need and impact of build-up the tensile force as well as spread and change over time, perhaps possible distances and/or time delay caused by mechanical deflections.
- 3.2 Possible design variants (also in combination):
- Remote release, protection against lowering, emergency limit switching
 - Installation in the shaft pit or suspended arrangement (console turned through 180°)
 - Governor wheel with cast-on toothed ring and governor bearing with drillings for pulse generator attachment
 - Optional attachment incremental pulse generator, rotary pulse encoder and magnetic switch
 - Overspeed governor with and without cover
 - Safety switch with electrical resetting
- 3.3 The overspeed governor can also be used to a counterweight in compliance with the permissible tripping speed.
- 3.4 This EU type-examination certificate was issued according to the following standards:
- EN 81-1:1998 + A3:2009 (D), Annex F.4, F.7 and F.8
 - EN 81-2:1998 + A3:2009 (D), Annex F.4 und F.8
 - EN 81-20:2014 (D), part 5.6.2.2.1.7, part 5.6.6.11 and part 5.6.7.13
 - EN 81-50:2014 (D), part 5.4, 5.7 and 5.8

A revision of this EU type-examination certificate is inevitable in case of changes or additions of the above mentioned standards or of changes of state of the art.

**Enclosure to the EU Type-Examination Certificate
No. EU-OG 068 of 2016-03-01**



Industrie Service

Authorised Manufacturer of Serial Production – Production Sites (valid from: 2016-03-01):

Company	BODE Components GmbH
Address	Eichsfelder Str. 29 40595 Düsseldorf – Germany

- END OF DOCUMENT -

as option cover according to EN 81
or cover according to Industrial Safety Regulation

protection against jump off the rope

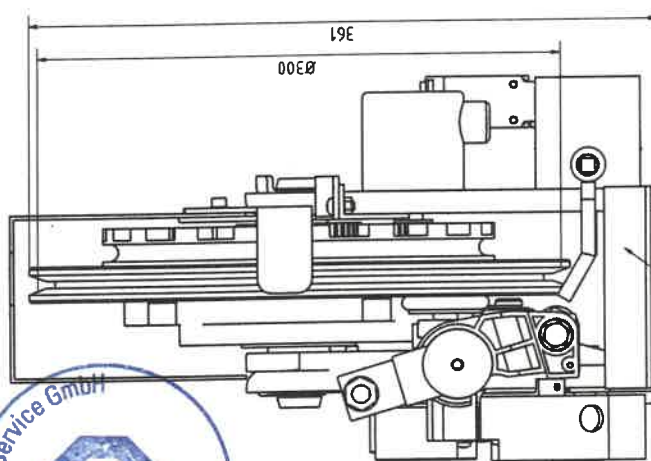

strengthening for hanging version
and VA \pm 1,30m/s

as option
jig wheel

as option
encoder

as option
auxiliary current final
limiting switch

as option
magnetic switch

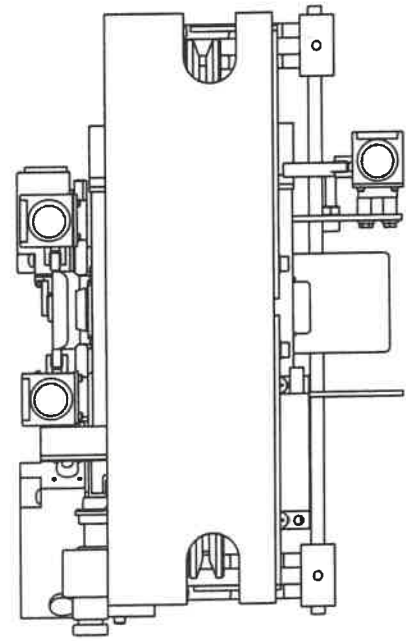

as option
hardened rope-groove

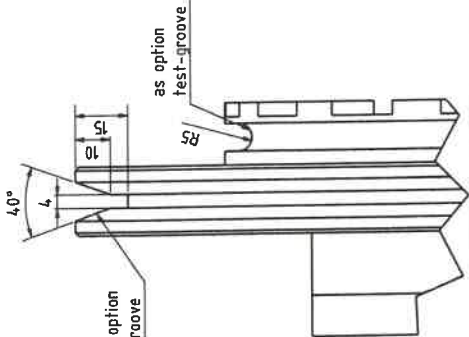

as option
fest-groove

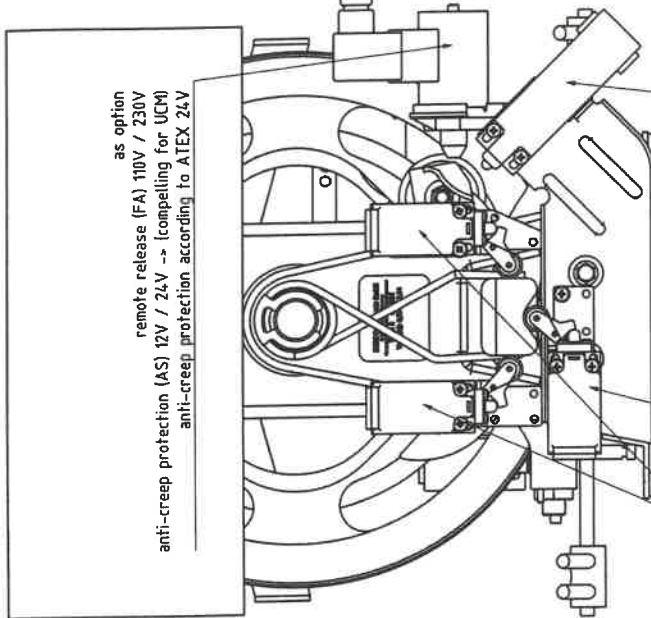

as option
remote release (FA) 110V / 230V
anti-creep protection (AS) 12V / 24V \rightarrow (compelling for UCM)
anti-creep protection according to ATEX 24V

as option
directional switch

standard safety switch /
safety switch according ATEX Vn < 1,00m/s
and additional for Vn > 1,00m/s incl. AS or FA

safety switch as pre-cut off switch
Vn > 1,00m/s

0 1. MRZ. 2016

GEPRÜFT / APPROVED
TÜV SÜD Industrie Service GmbH
Prüflaboratorium für Produkte der Elektrotechnik
Westendstraße 199
80688 München
Sachverständigen-Expert

BODE Components		Material:		Gewicht:	
Düselcode		over speed governor Type 7			
Algemeincode	DN ISO 2768 e				
Datum	Name				
Gezeichnet	38370000				
Geprüft	38370000				
Erreichte	9 5 07 1001				
Einkaufsnummer:		OSG Type 7 variants		Blatt: 1	
Eigenschaften		EU-06 068		VA 0,70m/s to 3,43m/s	
Norm		9 5 07 1001			
Skizze		Schweißcode		Sondercode	
3		4		5	

EU- Konformitätserklärung für Sicherheitsbauteile für Aufzüge gemäß
EU-Aufzugsrichtlinie 2014/33/EU

BODE
COMPONENTS

**EU- Declaration of conformity for safety components for lifts
according to the EU Lifts Directive 2014/33/EU**

Hiermit erklären wir, dass die nachfolgend aufgeführten Bauteile den Anforderungen der EU-
Aufzugsrichtlinie 2014/33/EU entsprechen.
**We hereby certify that the components described hereafter meet the requirements of the
EU Lift Directive 2014/33/EU.**

Name und Anschrift des Hersteller:
Name and address of Manufacturer:

BODE Components GmbH
Eichsfelder Straße 29
40595 Düsseldorf – Deutschland

Beschreibung / Funktion:
Description / Function:

Bidirektionaler Geschwindigkeitsbegrenzer für
Sperrfangvorrichtungen und Bremsfangvorrichtungen
**Bi-directional overspeed governor for progressive safety
gear**

Bezeichnung:
Type:

Typ 7, Typ 8, Typ 9
Seriennummer und Baujahr: Siehe Typenschild
Type 7, Type 8, Type 9
Serial number and production year: see label

Das Sicherheitsbauteil entspricht:
The safety component complies:

EN 81-1:1998+A3:2009
EN 81-2:1998+A3:2009
EN 81-20:2014, EN81-20:2020
EN 81-50:2014, EN81-20:2020

Benannte Stelle der Baumusterprüfung:
Notified Body of the type examination:

TÜV Süd Industrie Service GmbH
Westendstraße 199
80686 München – Deutschland
Kennnummer / **Identification No.** CE 0036

Baumusterprüfbescheinigungs Nr.:
Type examination no.:

Typ / Type 7: EU-OG 068
Typ / Type 8: EU-OG 069
Typ / Type 9: EU-OG 084

Benannte Stelle der Fertigungsstätten
Überwachung:
**Notified body of the production facility
monitoring**

TÜV Rheinland Industrie Service GmbH
Am Grauen Stein
51105 Köln – Deutschland
Kennnummer / **Identification No.** CE 0035

Ort und Datum:
Place and Date:

Düsseldorf, 23.02.2023

Bestätigung durch:
Confirmation by:

Volker Trein
Technischer Leiter / **Technical Director**